

FIGURE 3(a): PLAN
DESIGN TD ASI428-2-1992

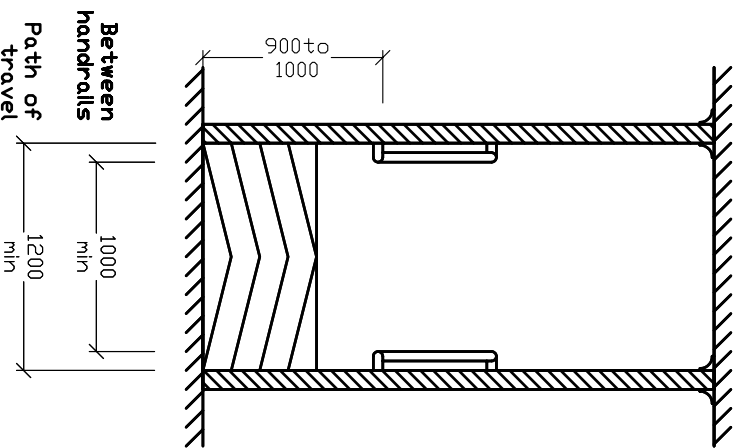

FIGURE 3(b): ELEVATION
DESIGN TD ASI428-2-1992

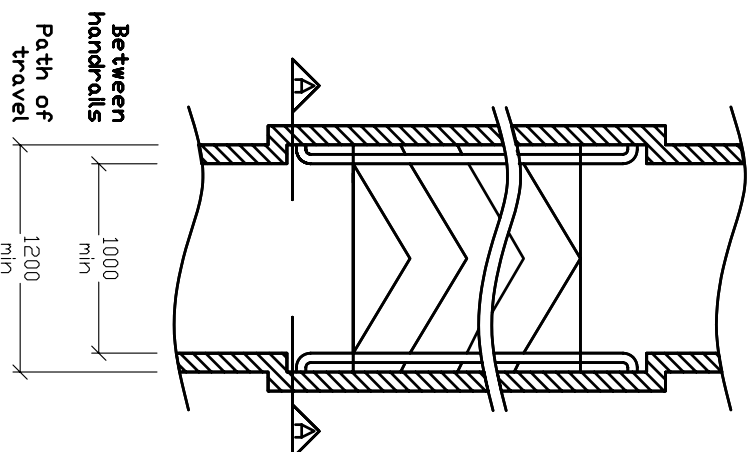

FIGURE 3(c): PLAN
DESIGN TD ASI428-1-2001

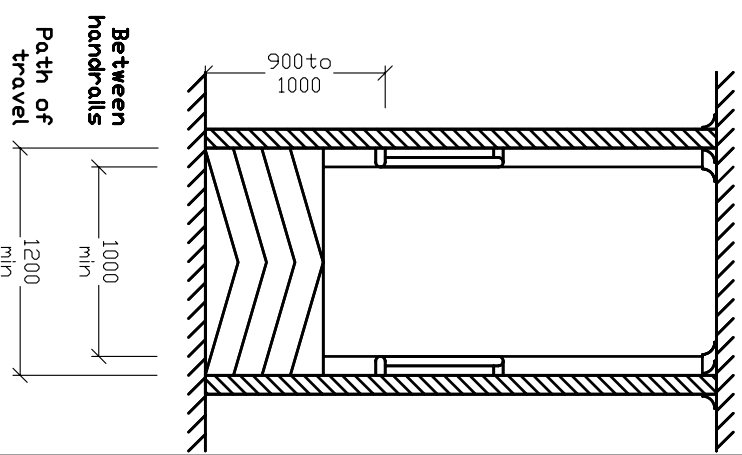

FIGURE 3(d): SECTION A-A
DESIGN TD ASI2428-1-2001

FIGURE 3: RAMPS

Building design on ASI428-2-1992 (Figures 3(a) and 3(b)) will provide suitable access for all users if ramp handrails are permitted to protrude 100mm into the path of travel. Building design based on ASI428-1-2001 (Figures 3(c) and 3(d)) will be expensive to construct and will not provide suitable access for all.
Note: This concession would not be acceptable at turns.